

DIGITAL BS TUNER

TBDU18132IMT

WRITTEN	CHECKED	APPROVED

SAMSUNG ELECTRO - MECHANICS CO. ,LTD.
314, MAETAN3-DONG, PALDAL-GU, SUWON, KYUNGKI-DO, KOREA

T E L : 82-31-210-3054, 6384

F A X : 82-31-210-6380

SPECIFICATION

1. GENERAL SPECIFICATION OF RF TUNER

1-1 Receiving Frequency	950 ~ 2150MHz																
1-2 RF Input Impedance	75 Ω																
1-3 Channel Selection System	Built in PLL (IIC Bus : TSA5059 or Equivalent)																
1-4 RF Input Connector	F Type (Female)																
1-5 Circuit Block Diagram	Figure																
1-6 PLL Step Size	Depending on PLL Setting																
1-7 Operating Voltage	<ul style="list-style-type: none"> ·LNB Power : (TYP) ·B+ (5V) : 5.0V DC (±5%) ·Tuning Voltage : 28.0V~33.0V DC ·AGC Voltage : 0V~5V DC <table border="1" style="margin-left: auto; margin-right: auto;"> <tr> <td>AGC Voltage</td> <td>0V</td> <td>5V</td> </tr> <tr> <td></td> <td>MAX GAIN</td> <td>MIN GAIN</td> </tr> </table>	AGC Voltage	0V	5V		MAX GAIN	MIN GAIN										
AGC Voltage	0V	5V															
	MAX GAIN	MIN GAIN															
1-8 Current Consumption in Tuner Part.	<table border="1" style="margin-left: auto; margin-right: auto;"> <thead> <tr> <th style="text-align: center;">\</th> <th style="text-align: center;">MIN</th> <th style="text-align: center;">TYP</th> <th style="text-align: center;">MAX</th> </tr> </thead> <tbody> <tr> <td style="text-align: center;">B_A (5V)</td> <td></td> <td style="text-align: center;">250mA</td> <td style="text-align: center;">300mA</td> </tr> <tr> <td style="text-align: center;">V_T</td> <td></td> <td></td> <td style="text-align: center;">2mA</td> </tr> <tr> <td style="text-align: center;">AGC</td> <td></td> <td></td> <td style="text-align: center;">5mA</td> </tr> </tbody> </table>	\	MIN	TYP	MAX	B _A (5V)		250mA	300mA	V _T			2mA	AGC			5mA
\	MIN	TYP	MAX														
B _A (5V)		250mA	300mA														
V _T			2mA														
AGC			5mA														
1-9 Temperature	<ul style="list-style-type: none"> ·Operating : 0°C to 60°C ·Storage : -20°C to 70°C 																
1-10 Humidity	<ul style="list-style-type: none"> ·Operating : less than 85 % ·Storage : less than 90 % 																

SPECIFICATION

2.ELECTRICAL SPECIFICATION OF THE RF TUNER

Test Condition		1. Supply Voltage 1-1 B+ (5V) : 5V ± 0.1V DC 1-2 Tuning : 28V ± 0.1V DC 2. Ambient Temperature : 25°C ± 5°C 3. Ambient Humidity : 65% ± 10%				
NO	ITEM	SPECIFICATION				CONDITION
		MIN	TYP	MAX	UNIT	
2-1	Input Level	-65		-25	dBm	
2-2	RF Input VSWR		2	3		
2-3	Noise Figure		6	12	dB	MAX. GAIN
2-4	3'rd order Intermodulation Rejection Ratio	40			dB	Desire -25 Undesire dBm
2-5	Local Oscillation Signal leakage at RF Input Terminal		-80	-63	dBm	
2-6	Gain Deviation		5	10	dB	950~2150 MHz
2-7	Phase Noise 10 KHz Offset Freq 100 KHz		-75 -95	-70 -90	dBc/ Hz	
2-8	I/Q Level Imbalance			±1	dB	I Relative
2-9	I/Q Phase Error		±2		DEG	
2-10	I/Q Baseband Flatness			±3	dB	
2-11	I/Q Output Level		500		mV _{p-p}	4.7KΩ Loaded
2-12	I/Q Output Impedence		470		Ω	

SPECIFICATION

3. PLL INFORMATION CONTROLLING VIA THE IIC BUS (TSA5059)

Table 1 Write data format (MSB is transmitted first)

	MSB						LSB			
ADDRESS	1	1	0	0	0	0	1	0	A	Byte 1
PROGRAMMABLE DIVIDER	0	N14	N13	N12	N11	N10	N9	N8	A	Byte 2
PROGRAMMABLE DIVIDER	N7	N6	N5	N4	N3	N2	N1	N0	A	Byte 3
CONTROL DATA	1	0	0	0	R3 (0)	R2 (1)	R1 (0)	R0 (0)	A	Byte 4
CONTROL DATA	C1 (1)	C0 (0)	0	0	0	P2	P1	0	A	Byte 5

Table 2 Read data format (MSB is transmitted first)

ADDRESS	1	1	0	0	0	0	1	1	A	Byte1
STATUS BYTE	POR	FL	×	×	×	×	×	×	-	Byte2

- A: Acknowledge bit
- N14 - N0: Programmable division ratio control bits
- P1: Oscillator frequency range select(see table 3)
- P2: P2 output port status
- POR: Power On Reset indicator
- FL: Phase Lock Flag
- R2,R1,R0: Reference Division Ratio Select(see table 4)
- C1,C0: Charge Pump Current Select(see table 5)

SPECIFICATION

3. PLL INFORMATION CONTROLLING VIA THE IIC BUS (TSA5059)

Table 3 P1 setting for VCO tuning

P1 status	OSC Frequency range
1	950 to 1550MHz
0	1550 to 2150MHz

Table 4. Reference division ratio

R3	R2	R1	R0	RATIO	R3	R2	R1	R0	RATIO
0	0	0	0	2	1	0	0	0	24
0	0	0	1	4	1	0	0	1	5
0	0	1	0	8	1	0	1	0	10
0	0	1	1	16	1	0	1	1	20
0	1	0	0	32	1	1	0	0	40
0	1	0	1	64	1	1	0	1	80
0	1	1	0	128	1	1	1	0	160
0	1	1	1	256	1	1	1	1	320

Table 5. Charge pump current

C1	C0	Current(typ.) in uA
0	0	120
0	1	260
1	0	555
1	1	1200

※. C1,C0 data should be considered with reference division ratio.

For example, we recommend C1C0=01 in 125kHz step size(R3R2R1R0=0100).

If you want to use 1MHz step, you'd better set C1C0=01.

Tuning frequency : $f_{VCO} = PC \cdot 4\text{MHz} / 32$

$= PC \cdot 125\text{kHz}$

(PC:scaling factor of programmable 15 bit-divider)

7. PLL TUNING CIRCUIT

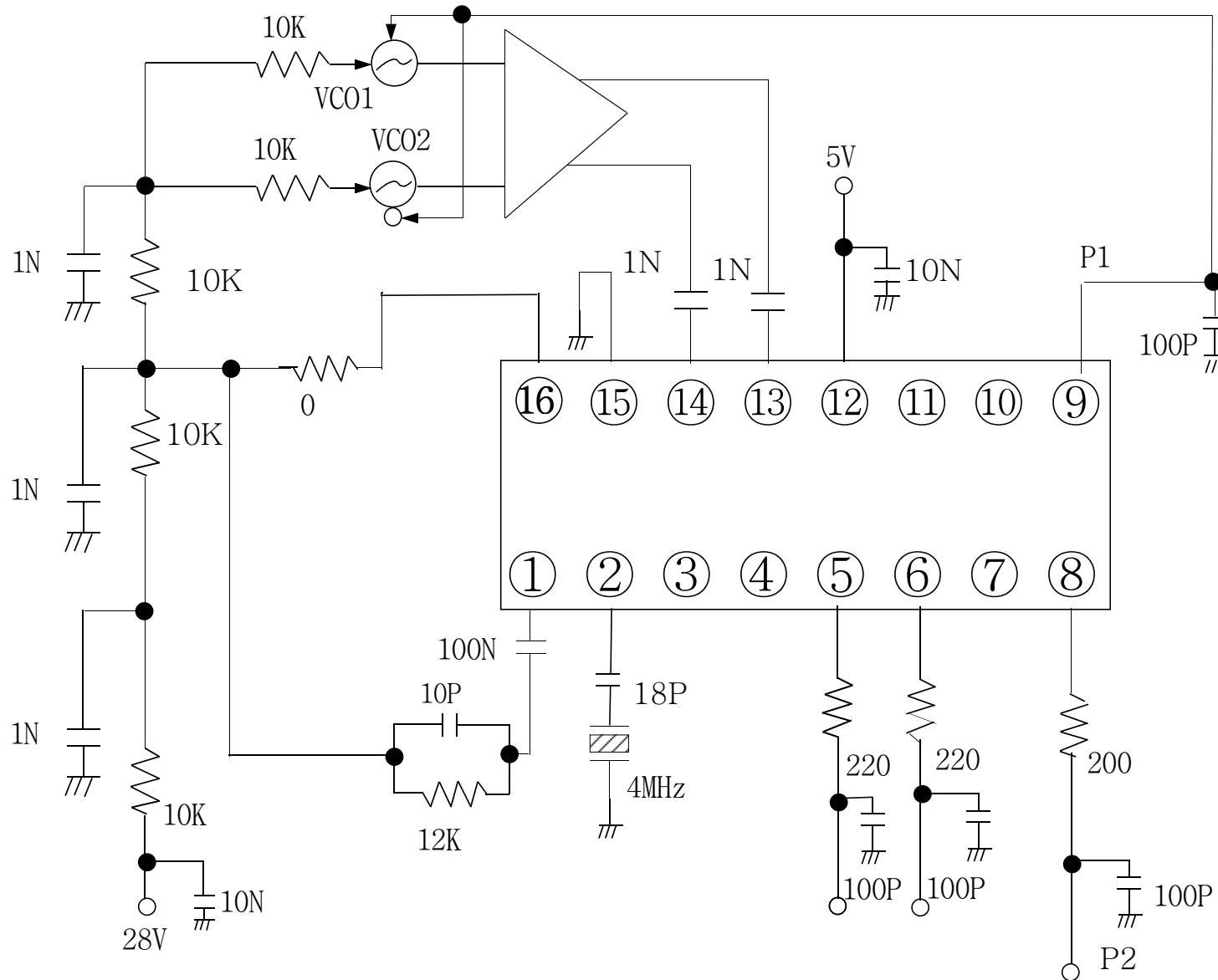

1. CHARGE PUMP
2. X-TAL
3. XT/COMP
4. AS
5. SDA
6. SCL
7. P3
8. P2
9. P1
10. PO
11. ADC
12. VCC
13. RF INPUT
14. RF INPUT
15. VEE
16. VT

8. BLOCK DIAGRAM

BS TUNER

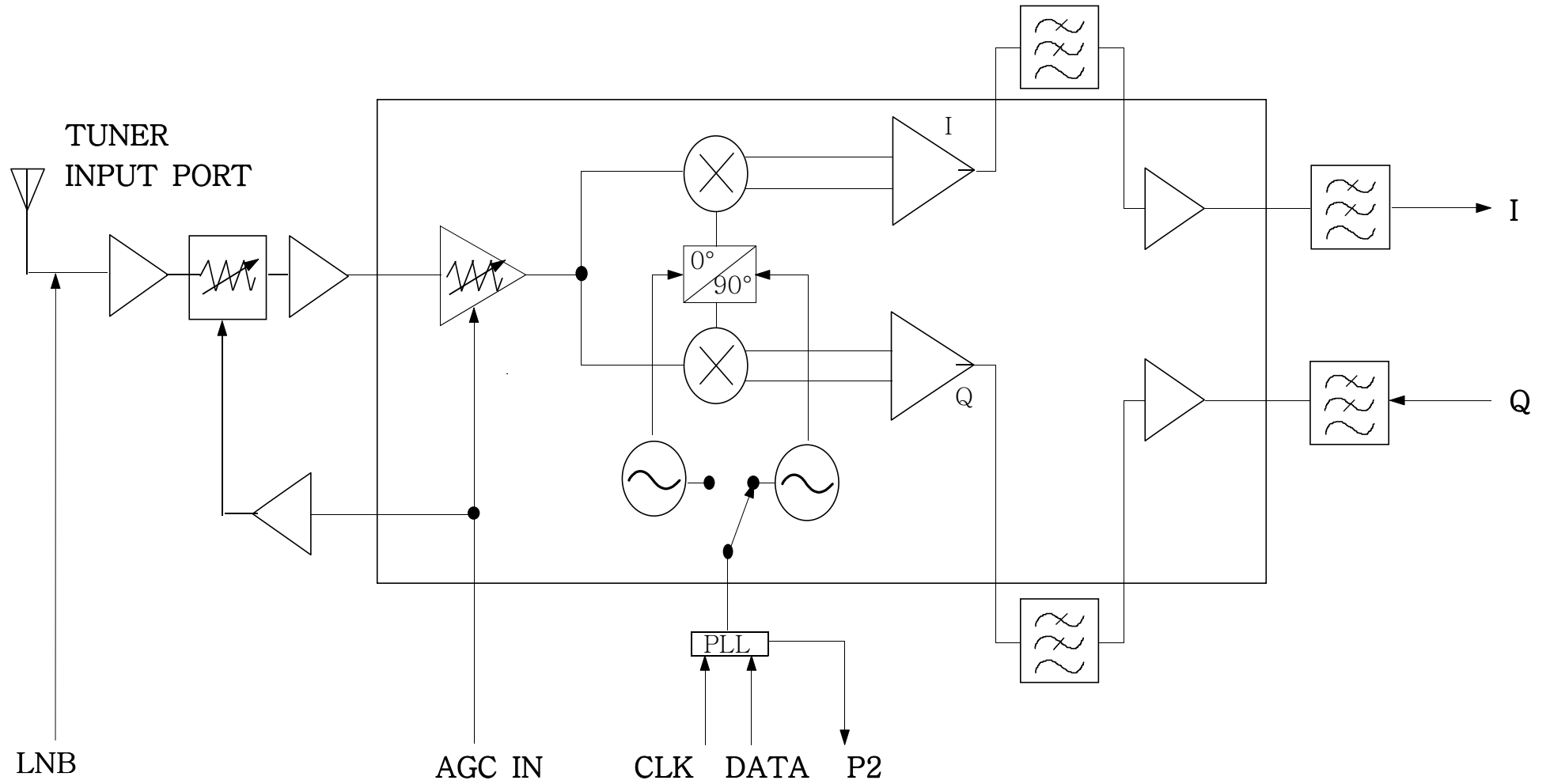

950M ~ 2150MHz

9. APPLICATION CIRCUIT

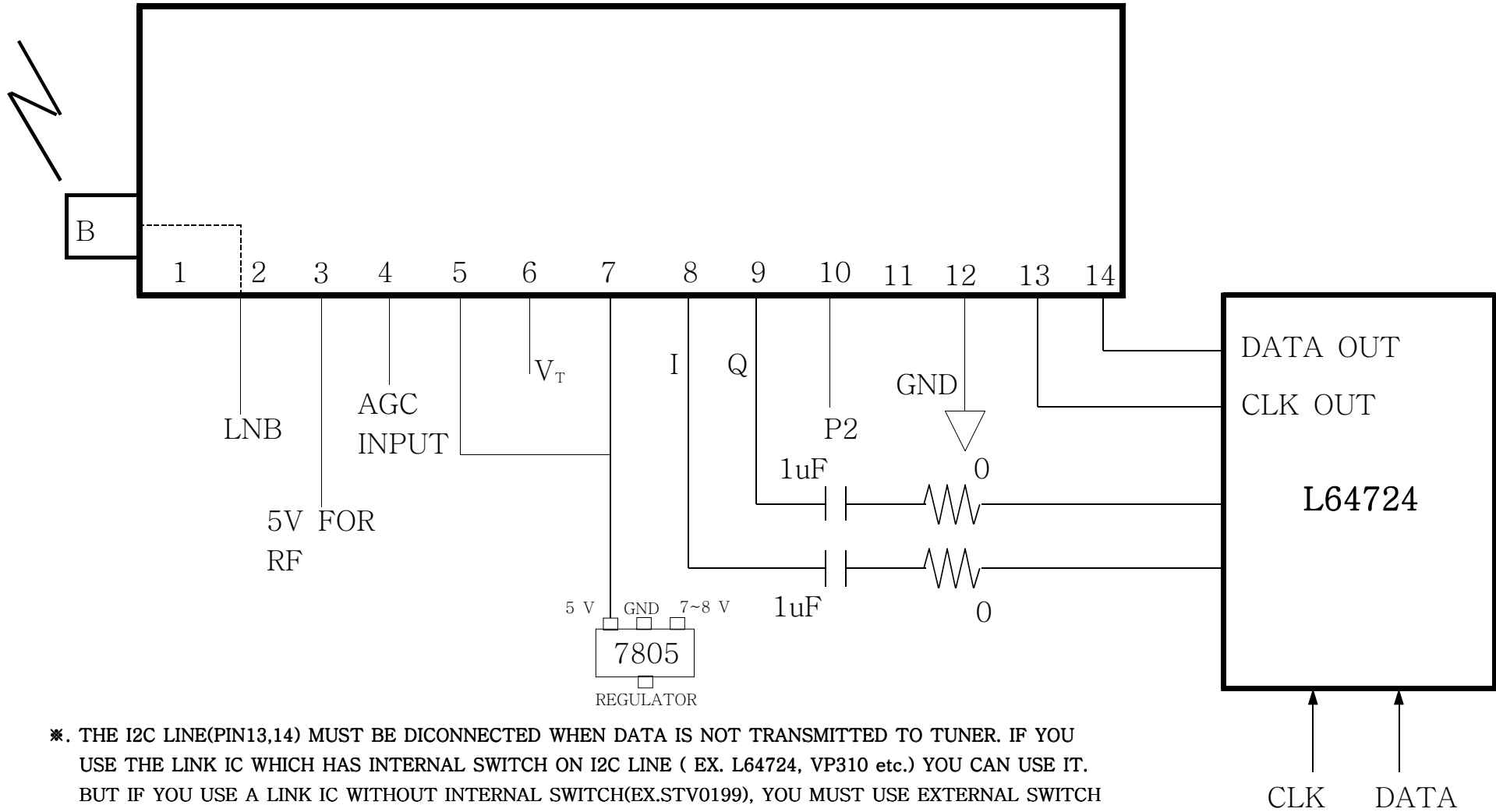

※. THE I2C LINE(PIN13,14) MUST BE DICONNECTED WHEN DATA IS NOT TRANSMITTED TO TUNER. IF YOU USE THE LINK IC WHICH HAS INTERNAL SWITCH ON I2C LINE (EX. L64724, VP310 etc.) YOU CAN USE IT. BUT IF YOU USE A LINK IC WITHOUT INTERNAL SWITCH(EX.STV0199), YOU MUST USE EXTERNAL SWITCH ON I2C BUS.

10. PIN DESCRIPTION

PIN NO	MARK	DESCRIPTION	CURRENT(TYPICAL)	RIPPLE (MAX)
1	NC			
2	LNB	LNB POWER INPUT TO TUNER INPUT PORT(A)		
3	5V(RF)	5V INPUT FOR 1'STRF-AMP & LOOP THROUGH (THIS PIN CAN BE USED FOR STAND-BY MODE.)	20mA	20mVp-p
4	AGC	AGC VOLTAGE INPUT		
5	5V	5V INPUT FOR THE OTHER RF AMPS & ZERO-IF IC	T.B.D.	20mVp-p
6	VT	30V TUNING VOLTAGE INPUT		
7	5V	5V INPUT FOR ZERO-IF IC & PLL IC & OSC	T.B.D.	20mVp-p
8	I	I SIGNAL MONITORING		
9	Q	Q SIGNAL MONITORING		
10	PORT2	I/O PORT OF PLL IC		
11	NC	NO CONNECTION		
12	GND	PIN GROUND		
13	CLOCK	CLOCK BUS		
14	DATA	DATA BUS		

A4

NO	PART NAME	Q'TY	MATERIAL	FINISH	REMARK
	OUTLINE DRAWING				

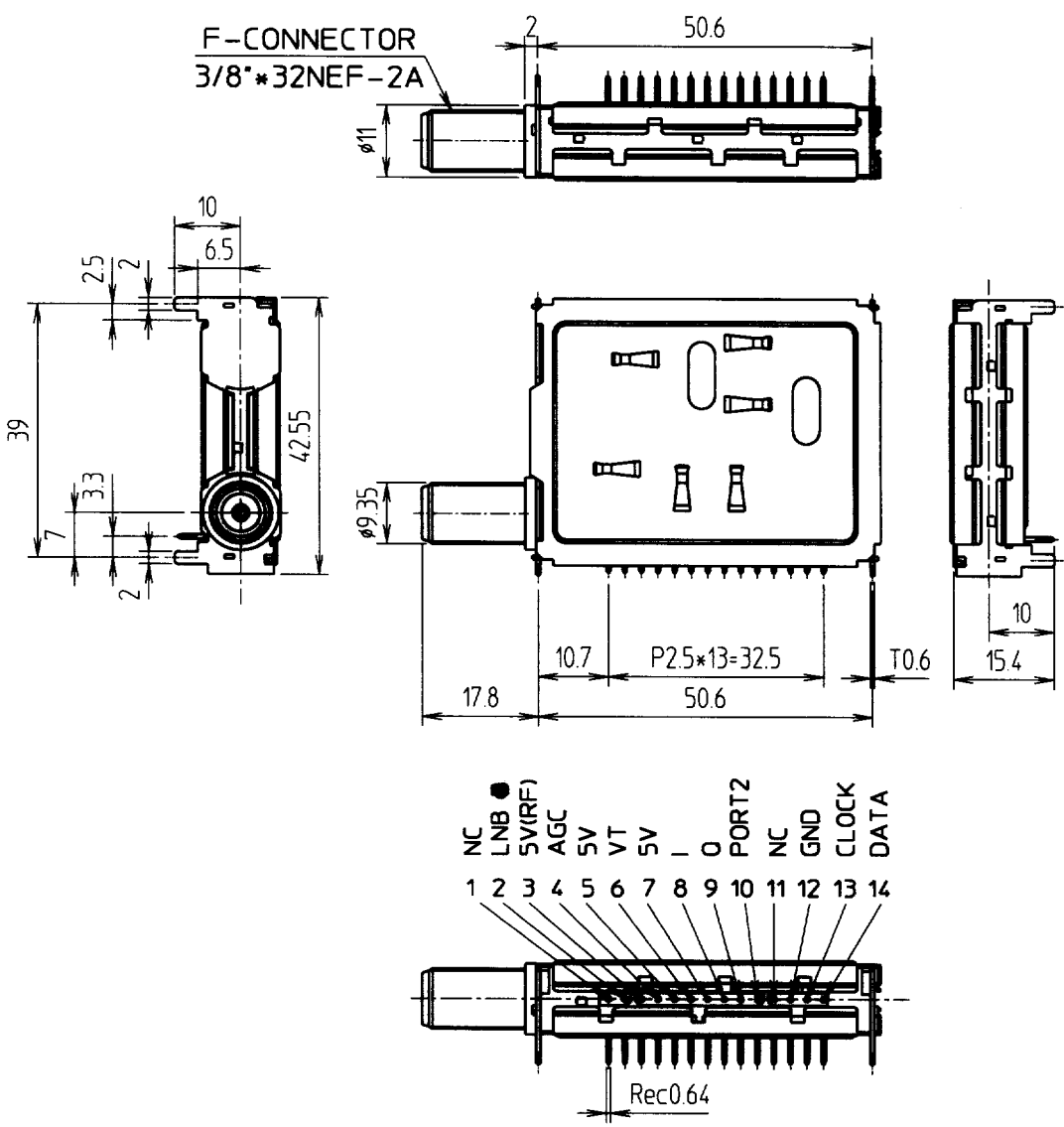

* MAIN PCB HOLE SIZE : $\phi 1.2$ (MIN)

Rev		DATE	WRITTEN BY	CHECKED BY	REVISION RECORD			REMARK
JNT	$\frac{m}{m}$	DRAW	DESIGNED	CHECKED	APPROVED	NAME	PART NAME	OUTLINE DRAWING
SCALE	$\frac{1}{1}$		LIM				MODEL NAME	BS-TU 10 SERIES
TOLERANCE	± 0.5		2000.03.02				SEMCO P/N	TBDU18132IMT
SAMSUNG		File name	TBDU18132IMT			NC		
ELECTRO-MECHANICS		3RD ANGLE PROJECTION						

A4